



# PLEDGER

Paving the way for next-generation edge computing

Issue 6/November-December 2022

pledger-project.eu

## IN THIS ISSUE

- About PLEDGER
- Challenge and Solution
- Latest Demos & Articles in our Blog
- News & Events
- PLEDGER open code repository

## FOLLOW US:

- @pledgerproject
- @pledgerproject
- Pledger Project

## KEY FACTS

- PROJECT NAME:** PLEDGER: Performance optimization and edge computing orchestration for enhanced experience and Quality of Service
- GRANT AGREEMENT NO:** 871536
- TOPIC:** ICT-15-2019-2020
- CALL:** H2020-ICT-2018-20
- FUNDING SCHEME:** Research & Innovation Action (RIA)
- FUNDED UNDER:** H2020 Framework
- DURATION:** 36 months

## ABOUT PLEDGER

**PLEDGER is a new project coordinated by ATOS Spain. It is funded by the European Union's Horizon 2020 research and innovation programme.**

The project aims to deliver a new architectural paradigm that will pave the way for next-generation edge computing infrastructures, tackling the modern challenges and coupling the benefits of low latencies on the Edge with the robustness and resilience of cloud infrastructures. It will also allow edge computing users to understand the nature of their applications, research understandable quality of service metrics and optimise the competitiveness of their infrastructures.

Enjoy reading all about the PLEDGER project!

## CHALLENGE AND SOLUTION

**One of the main drawbacks and hindering factors in the process envisioned by PLEDGER is the lack of cross-layer knowledge and the inability to exchange it that are enforced upon the involved roles:**

**THE IAAS PROVIDERS** that require improved awareness on the types of applications executed by their customers,

**THE ADOPTERS/CONSUMERS** (e.g. SaaS providers) of infrastructure services, that require improved awareness on the types of physical nodes their applications will be executed on.

PLEDGER introduces necessary improvements across this value chain by following a black box approach in all the involved layers, in order to adapt to the specifics of the ecosystems in question and the corresponding lack of knowledge. The proposed approach does not assume any kind of Adopter-Provider interaction, but all the necessary information is extracted via non-intrusive methods abiding to this role separation imposed by the Cloud business model.

## LATEST DEMOS & ARTICLES IN OUR BLOG



**DATA PRIVACY MOBILITY EDGE COMPUTING** Data privacy is being one of the most recur-rent discussion topics when talking about smart solutions that try to solve citizen's needs. In last years, the new GDPR regula-tion pushed existing and new smart solutions to find the right formula to develop custom-ised services while ensuring data privacy. When considering mobility services, geo-localisation issues are commonly added on top of that formula so it has to be carefully analysed in addition to the rest of the existing features.

Read about it in our [blog](#).

Visit our demos on Youtube: [5G Slice Deployment](#), [RAN Monitoring](#), [V2X Slicing](#).

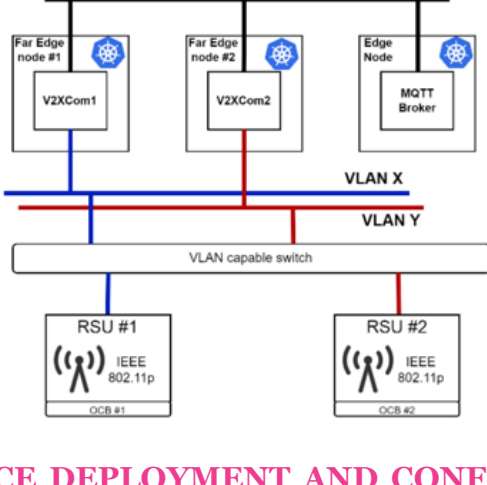

**NETWORK SLICE DEPLOYMENT AND CONFIGURATION IN PLEDGER** Network slicing can provide dedicated and isolated compute, network, and radio resources according to specific quality of service (QoS) requirements of applications. In Pledger, the SOE and RAN Controller components work together to add network slicing capabilities to the core platform.

Read about it in our [blog](#).

Visit our demos on Youtube: [5G Slice Deployment](#), [RAN Monitoring](#), [V2X Slicing](#).

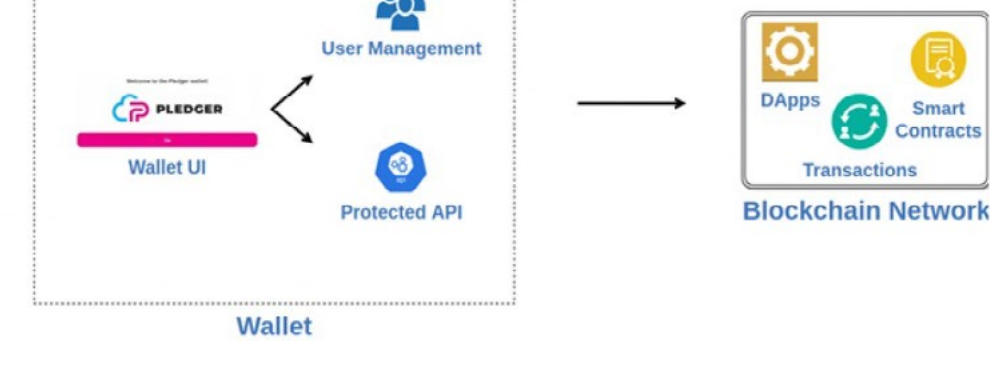

**ENABLING CONFIDENTIAL DATA ACCESS FOR TRUSTED USERS IN PERMISSIONED BLOCKCHAIN NETWORKS THROUGH WALLETS** Blockchain wallets determine the de facto way for a user to interact directly with their dedicated data on the ledger. In principle, wallets provide a layer of specified data access as defined with regards to the corresponding functionalities that should be offered to the users that log in. However, in permissioned networks, data access is de-termined by the corresponding tools made available to the interested users who owe to adopt and utilize in every case of network design and deployment. In Pledger, the re-search direction towards standardizing the data access with strong confidentiality features, presents a private-access wallet that enables confidential data access to trusted users.

Read about it in our [blog](#).

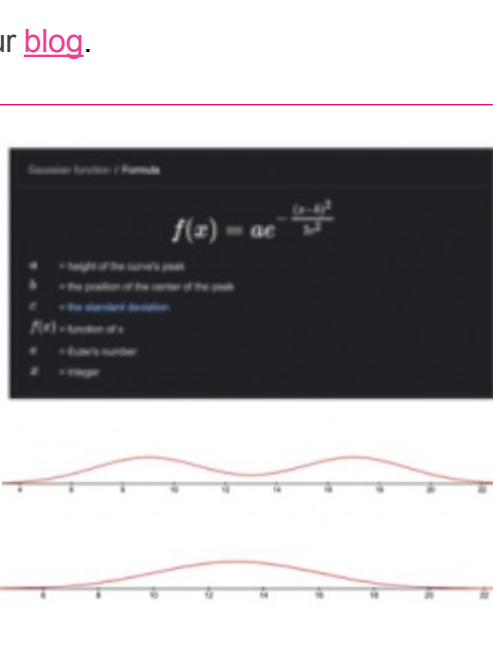

**SMART SCHEDULING TO OPTIMIZE RESOURCES AND LATENCY ON CLOUD-EDGE AND ENERGY ON EDGE NODES** Edge computing brings to applications orchestration additional requirements such as local data processing, lower network latency and improved resiliency and autonomy to overcome unattended and disconnected operations. Kubernetes orchestration and its open-source implementations for the edge help to increase the resiliency and autonomy with automatic scaling, self-monitoring and balancing and thousands of production-ready tools and applications.

Read about it in our [blog](#).

Visit our demo on [YouTube](#).

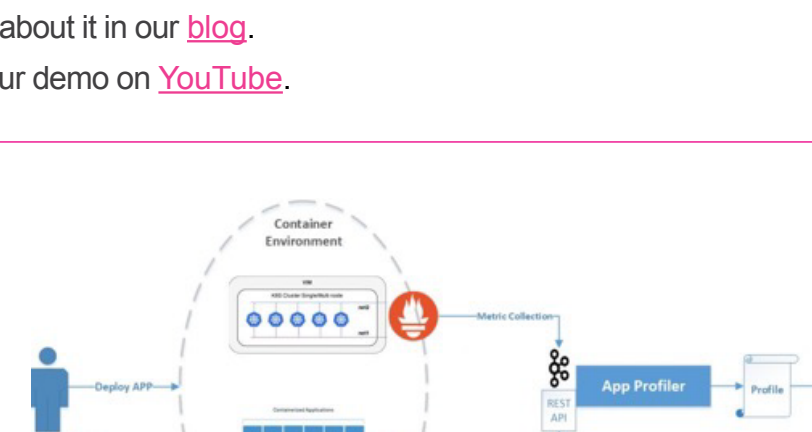

**UNDERSTANDING APPLICATION RESOURCE REQUIREMENTS THROUGH PROFILING** A new trend in data-intensive software applications requires their deployment in a public or private Cloud provider mixed with an Edge solution, with the goal of leveraging various dispersed resources of an Infrastructure as a Service (IaaS). However, several significant challenges are highlighted prior to most applications' migration to a Cloud/Edge-based version, such as the provider or virtual resource (VMs) resource size selection, in order to achieve particular Quality of Service (QoS) requirements, thus meeting the application needs. Migrating to a cloud infrastructure can provide economic, performance, and strategic benefits, but it must be done with caution and care.

Read about it in our [blog](#).

Visit our demo on [YouTube](#).

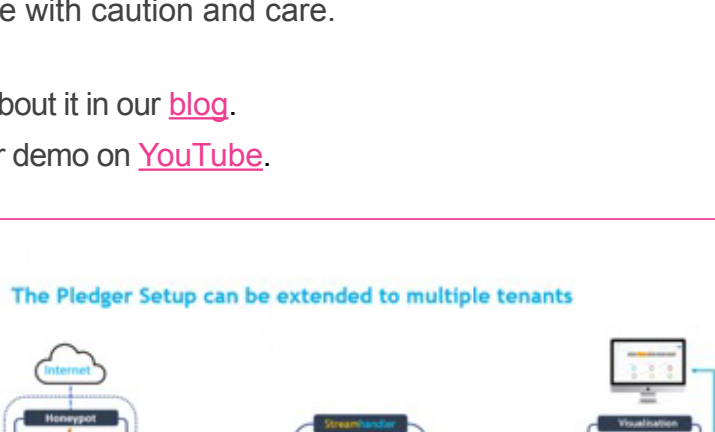

**THE PLEDGER VIRTUALISED SECURITY SERVICES ARCHITECTURE** As the volume of malicious traffic continues to rise and new threats emerge every day, cyberattacks are becoming increasingly dangerous and sophisticated. When organisations want effective and simple tools to monitor and protect their systems from being hacked, various cybersecurity technologies come to the rescue. In the case of the Edge-Cloud environment that forms the basis of the Pledger architecture, its dynamic, service-oriented nature creates additional challenges, as the environment is prone to frequent change.

Read about it in our [blog](#).

Visit our demo on [YouTube](#).

## EVENTS

**PLEDGER, RAINBOW AND MORPHEMIC PROJECTS PRESENT THEIR OUTCOMES AT THE BIG DATA VALUE FORUM 2022**



PLEDGER, within the context of its liaison activities, co-organized a panel event in collaboration with the EU-funded RAINBOW and MORPHEMIC projects on November 23, 2022. The event was organized by the Big Data Value Association and gathered multiple experts across Europe.

The panel discussion, titled "Next-generation platforms for Europe's Cloud Continuum" was dedicated to the Cloud Continuum as a strategic enabler of digital capabilities in the post-pandemic era. The panel discussed opportunities for boosting data-driven digital transformation of the EU innovation landscape and strengthening its competitiveness by leveraging on the next-generation Cloud Continuum platforms developed by the three EU-funded Cloud Computing projects.

**STAY TUNED FOR MORE TO COME AND DO NOT FORGET TO CHECK OUT OUR PUBLIC REPOSITORY AT [HTTPS://GITLAB.COM/PLEDGER](https://gitlab.com/pledger)**



This project has received funding from the European Union's Horizon 2020 research and innovation programme under grant agreement No 871536